

DPC

DRENA-LINE CLEAN WATER

- Compact and easy to handle
- Continuous operation
- Integrated float switch
- Manual-automatic switch
- Low level pumping
- Moisture sealed cable inlet



DESCRIPTION

The submersible pumps of the DPC series for clear water are designed for domestic use such as the drainage of infiltrated water, the collection of water from wells, basins or tanks. Check valve and hose connector adaptable for hoses of 3/4 or \varnothing 25-32, included in supply.

Minimum drying level 2 mm.

APPLICATIONS

- Drainage of infiltrated water, lifting of rainwater from grille or well
- Emptying of rooms, tanks and wells

PERFORMANCE

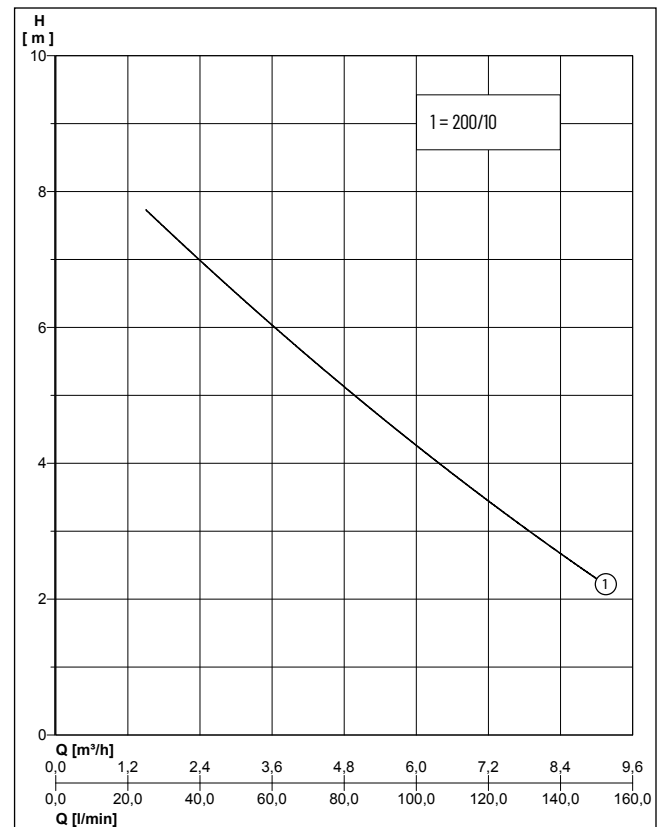

Type	Delivery head H [m]	3	4	5	6	7	8	9
DPC 200/10	Flow rate Q [m³/h]	7.7	6.4	4.7	3.5	2.5	1.5	0.7

DPC

DRENA-LINE - CLEAN WATER

MECHANICAL DATA

Free passage	5 mm	Submersible	Yes
Oil chamber	Yes	Mechanical seal	Graphite. Lubricated in oil chamber
Shaft	Stainless steel X 8 CrNi 18-9 (AISI 303)	Contourface	Ceramic. Lubricated in oil chamber
Impeller	Technopolymer	Temperature of the liquid max.	40 °C
Motor housing	Stainless steel X 8 CrNi 18-10 (AISI 304)	Diving depth	7 m
Pump housing	Technopolymer	Weight	5.6 kg

ELECTRICAL DATA

Voltage	1/N/PE~230 V	Type of enclosure	IP 68
Motor rating P1	0.65 kW	Insulation class	F
Current	2.9 A	Plug	Schuko
Power line	10m H05RN-F	Rotation speed	2850 rpm

DPC

Type	Code No.
DPC 200/10	N1080110

DPC

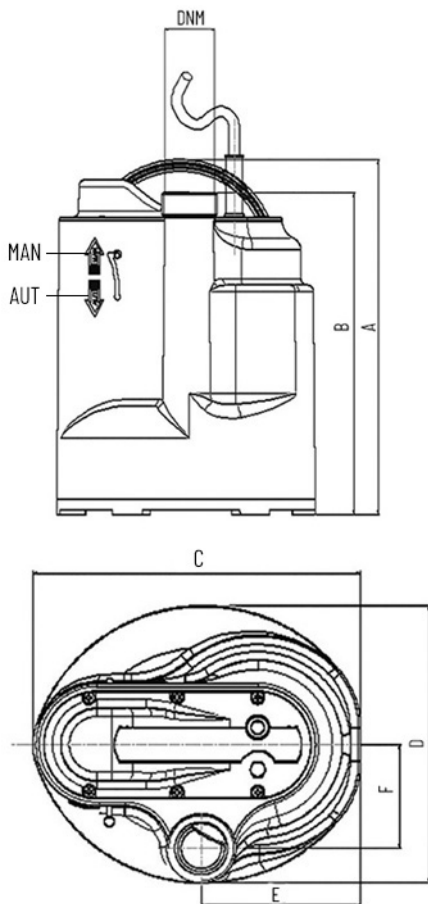

DIMENSIONS [mm]

Type	A	B	C	D	E	F	DNM
DPC 200/10	273	148	200	170	97	63	1 1/4"